





All Lighting Design and Design Elements are ©2011 by Jonathan Browning Studios, Inc.

VENTOUX TABLE LAMP

DESCRIPTION

The Ventoux Table Lamp is machined from solid brass. All parts are hand polished and plated. The metal shade is turned by hand on a lathe.

FINISHES

Shown in Oil-rubbed Bronze (standard). Also available in Satin Nickel, Polished Nickel and Lite Antique Bronze. Please note: All finishes may vary slightly.

SHADE

Metal. Also available in Clear Glass or Frosted Glass.

MODEL

1131

DIMENSIONS

6" Diam. x 32 H

NET WT.

9 lbs

ELECTRICAL

1x E12 - 60w max - LED Available

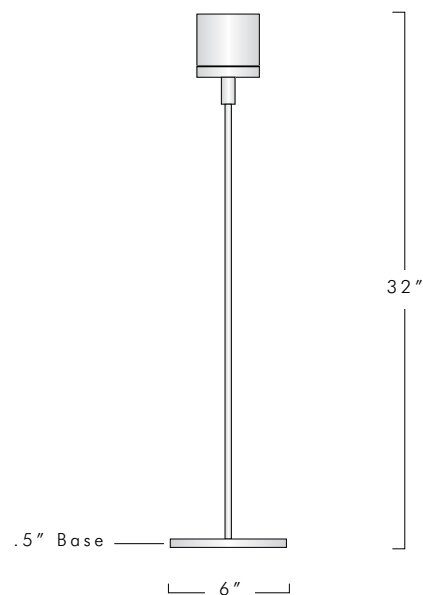

DIMMABLE
2700K